

# Utilisation of a Bioreactor for Culture and Expansion of Epithelial Cells without the use of Trypsin or Enzymes

Atsuko MIYAZAWA<sup>1,2</sup>, James WASHINGTON<sup>1</sup>, Eve L. BINGHAM<sup>1</sup>, Shiuhyang KUO<sup>1</sup>, Stephen E. FEINBERG<sup>1,3</sup>

**Objective:** To develop a bioreactor for automated culture, maintenance, and collection of normal human keratinocytes using an enzyme-free propagation method.

**Methods:** The culture of normal human epithelial keratinocytes was compared in two culture methods – a study team-developed automated bioreactor utilising an enzyme-free passage method, and a manual culture method. Cell size, glucose utilisation, and the proliferative capacity of the two cultures were evaluated.

**Results:** An automated bioreactor, not using enzymes for passage, but instead using the novel Epithelial Pop Up Keratinocytes (ePUK)<sup>1</sup> culture technique, resulted in an extended culture longevity and proliferative capacity in normal primary human keratinocytes. Daughter cells were collected up to three times per day utilising the bioreactor. The daughter cells produced by the bioreactor were smaller than daughter cells produced by the manual culture method. The proliferative capacity and health of the parent monolayer within both the bioreactor and the manual culture flask was dependent upon sufficient glucose availability. Due to the contact inhibition nature of epithelial keratinocytes, the bioreactor enabled the study of an adherent cell type soon after cytokinesis and before the cell has integrated as part of an adherent matrix.

**Conclusion:** The study demonstrates that increasing the number of media changes per day as necessary, based on glucose utilisation, is necessary for prolonged longevity and functional productivity of ePUK cultures.

**Key words:** bioreactor, cytokinesis, epithelial, glucose, keratinocytes  
*Chin J Dent Res* 2018;21(1):21–29; doi: 10.3290/j.cjdr.a39915

The development of the field of tissue engineering/regenerative medicine has necessitated the ability to grow large numbers of specific populations of cells in a time-efficient and cost-managed manner. Automation of cell culture for growing large numbers of adherent cells, such as epithelial cells, of the skin and oral mucosa can provide labour cost savings and improvements in cell quality to the field of tissue engineering/regenerative

medicine. The availability of defined culture media formulations and improved culture technologies based on current knowledge of specific cell types has made it possible to manufacture laboratory-produced tissues, with specific cell populations, for use in patient treatment<sup>2</sup>.

In order to facilitate the production of larger pieces of tissue, such as oral mucosa equivalents<sup>3</sup>, there exists the necessity to grow large quantities of cells. The number of cells is not the only important consideration. The cells must be healthy, i.e. undifferentiated and prolific, in order to produce a durable and viable tissue equivalent. When growing cells in a laboratory for production of an investigative product, it is also important to implement controls, ensuring the culture process yields a high quality cell/tissue product free of contamination. Technician errors such as sterility breach<sup>4</sup> or missing a scheduled maintenance can impact the quality of data and are a concern in the manufacture of any living

1 Department of Oral and Maxillofacial Surgery, School of Dentistry, University of Michigan, Ann Arbor, MI, USA.

2 Department of Oral and Maxillofacial Surgery, The Nippon Dental University School of Life Dentistry at Tokyo, Tokyo, Japan.

3 Department of Surgery, Medical School, University of Michigan, Ann Arbor, MI, USA.

**Corresponding author:** Dr Stephen E. FEINBERG, Department of Oral and Maxillofacial Surgery, University of Michigan, 1150 W Medical Center Drive, MSRB 2, A560B, Ann Arbor, MI, 48109, USA. Tel: 734 763 5963; Fax: 734 763 6199. Email: sefein@umich.edu

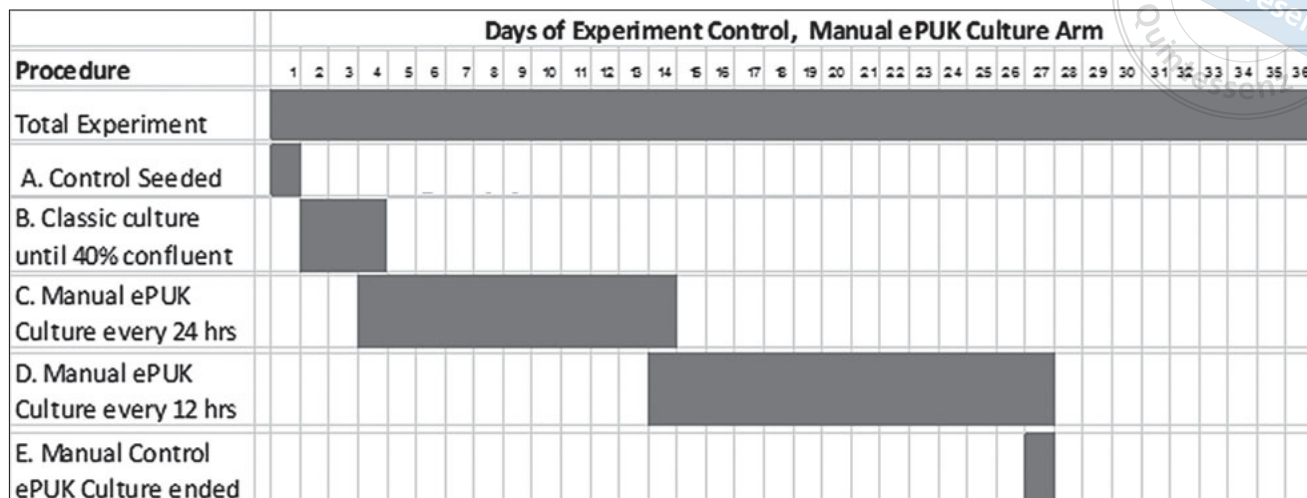
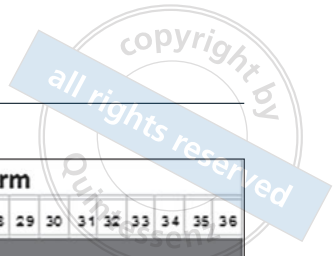

Fig 1 Timeline of the manual ePUK control culture arm of the study.

tissue product used for human implantation. A fully automated and self-contained bioreactor may add an element of control to reduce the incidence of technician error during cell culture and create a more cost effective and higher level of efficiency in cell production. This article describes the development of a bioreactor for controlled production of keratinocyte cells based on our novel ePUK (epithelial Pop Up Keratinocytes) culture technique<sup>1</sup>. ePUKs originate from a monolayer of keratinocytes grown under large volumes of serum-free, low calcium, chemically defined medium that is replaced every 24 h. Once densely confluent, the keratinocyte monolayer produces cells in suspension, into the overlying medium, that can be harvested every 24 h. The cell suspension is poured into new flasks to create subcultures. Exploiting the characteristic of over-confluent skin cell cultures to produce floating daughter cells by virtue of innate contact inhibition permits an enzyme-free and automated bioreactor method for mass production of these cells. In this article we discuss preliminary studies in the development of such a bioreactor.

**Materials and methods**

*Procurement, isolation, and cryopreservation of human primary skin keratinocytes*

The Institutional Review Board at the University of Michigan approved the procurement and use of discarded tissue from breast reduction surgeries for research. Keratinocyte cells from full thickness human skin were

isolated using the methods previously described<sup>5</sup>. The isolated keratinocytes were plated at a cell density of  $2.0$  to  $3.0 \times 10^6$  cells/ml in EpiLife media, Gibco, M-EPIcf-500, (Gaithersburg, MD, USA) with 2% foetal bovine serum, FBS, Gibco, 10082-147, (Gaithersburg). The plated cells were incubated at 37°C and 5% CO<sub>2</sub> for 24 h before the media was changed to EpiLife without any serum. The cells were fed every other day until they reached a confluence of 70% to 80%. They were then cryopreserved at  $2 \times 10^6$  cells/ml in EpiLife media with 20% FBS and 10% dimethyl sulfoxide.

*Thawing of cryopreserved cells and initiation of cultures*

On day 1, a vial of the cryopreserved cells was thawed, washed, and seeded at  $1 \times 10^6$  cells into each of two culture flasks with parallel, but different, culture timelines (Figs 1 and 2). One flask was the control flask, a 75 cm<sup>2</sup> culture flask (Corning 430641), which was used for the manual ePUK control culture. The second identical culture flask was modified by the addition of hoses for use as the bioreactor flask (BF) (Fig 3).

*Modification of culture flask for use as the bioreactor flask (BF)*

The bioreactor flask (BF) was made by modifying a standard 75 cm<sup>2</sup> tissue culture flask (Corning 430641) (Fig 3). For the first 4 days both the BF and the control arm flask are cultured under the same time line using the classic culture method. After the fourth day, a second type of modified cap for the BF is used. The customised cap for the BF is modified by drilling to enable a flush fit

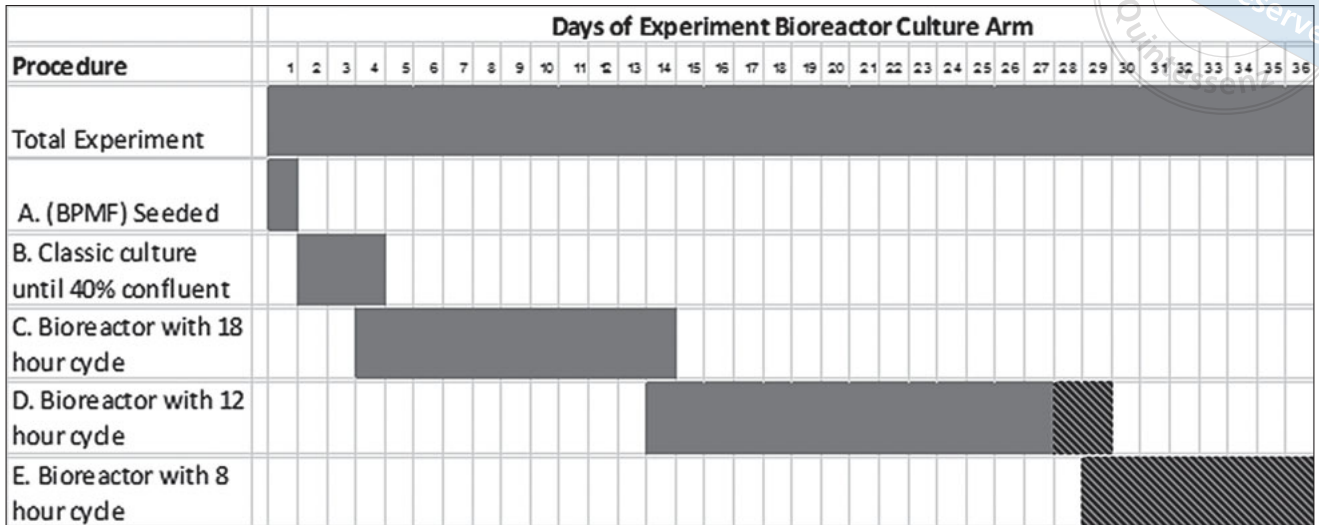

**Fig 2** Timeline of the bioreactor culture arm showing the progressive steps of the study. The cross-marked region, days 28 through to 36, are specific to the bioreactor arm of the study.

with a 4-inch piece of 5/16-inch outer dimension Tygon tubing 3350 (Saint-Gobain, Malvern, PA, USA). Tygon tubing with an inner dimension of 3/16-inch and an outer dimension of 5/16-inch was chosen for direct attachment and interaction with the BF due to its tensile strength and resistance to stretch. There is a flush seal between the 4 inches of tubing extending from the cap, and the interior of the cap. The cap and tubing are glued together and the vent holes are sealed using Gorilla Glue epoxy (5242742001). The modified cap is then packaged for ethylene oxide sterilisation and retained until needed at day 4. Next, two holes are drilled through the top of the BF using a Lenox 5/16-inch diamond hole saw drill bit. One hole is drilled in the centre of the BF for the fresh media delivery line. A second hole is drilled at a point furthest from the cap of the BF for the 5% CO<sub>2</sub> 95% airline. A 7-inch piece of the 5/16-inch outer diameter Tygon 3350 tubing is inserted into the fresh media hole to minimally breach the interior of the flask, and then glued with epoxy. A four-inch piece of 5/16-inch outer diameter Tygon 3350 tubing is inserted into the gas hole to minimally breach the interior of the flask and glued with epoxy. After the epoxy has cured the exposed ends of the tubes wrapped with cheese cloth, this modified flask is packaged and ethylene oxide sterilized. After sterilisation it is used for cell seeding for use in the bioreactor as described. The cheesecloth protects the aseptic integrity of the flask during the four days of classic culture (Figs 1 and 2). In order to maximise the effects of bioreactor cell culture maintenance within this experiment, the bioreactor flask was integrated with the bioreactor system when the BF cell density reached 40% confluence.

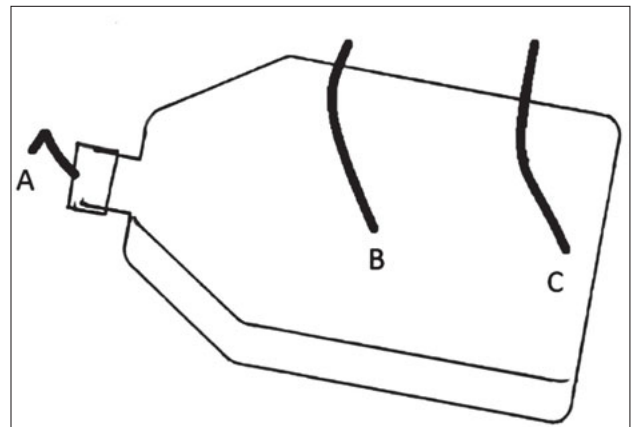

**Fig 3** Modification of flask to create bioreactor flask, BF: A Corning 75 cm<sup>2</sup> tissue culture flask was modified by addition of three Tygon tubing lines: Aspiration line through which air constantly flows out of the bioreactor flask. When the bioreactor flask is rocked to a 30 degree angle the used media and ePUKs are harvested by positive air pressure through the A line. Media fill line B delivers fresh media to the bioreactor flask at adjusted intervals every 18 h, 12 h, or 8 h. Gas line C delivers a constant flow of pressurized gas 5% CO<sub>2</sub> and 95% air to the bioreactor flask.

#### Classic cell culture method

In a 37°C incubator with 5% CO<sub>2</sub> cells in both flasks – the BF and the manual ePUK control culture arm flask – were cultured identically using the classic culture method for the first four days. Medium (EpiLife with EDGS, Gibco, S-012-5, Gaithersburg,) was exchanged every 48 h, with a volume of media equal to one-fifth of the surface area of the flask until the cell density reached 40% (Figs 1 and 2).

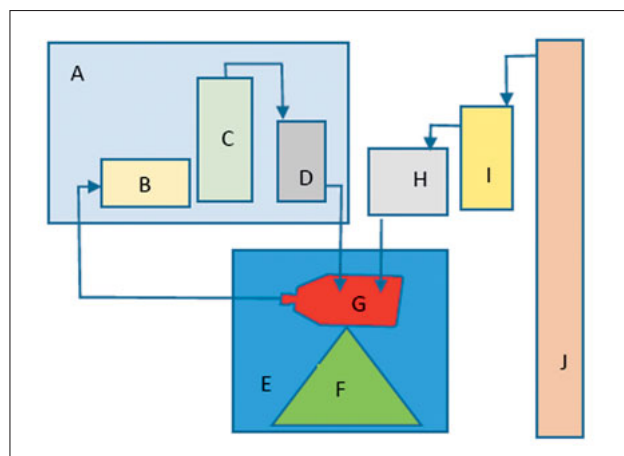

**Fig 4** Bioreactor System Schematic Representation: (A) Laminar flow hood BSL2 houses the ePUK harvest flask (B), and the fresh media reservoir (C). The peristaltic pump (D) can be housed inside or outside of the laminar flow hood, but is depicted within the flow hood. The peristaltic pump is used to pump fresh media from the fresh media reservoir and into the bioreactor flask at each feeding interval. The incubator (E) maintains a temperature of 37°C and houses the rocker (F), and the bioreactor flask (G). (J) a pressurised gas cylinder with a pressure regulator that provides a constant flow of premixed gas of 5% CO<sub>2</sub> and 95% air to the rotameter (I), which reduces the gas volume rate before the gas is filtered through the inline filter (H) and into the bioreactor flask (G).

### Manual ePUK control culture method

Cells in the manual ePUK control culture arm of the study were cultured within a 37°C incubator with 5% CO<sub>2</sub> and manually fed on each of two feeding cycles every 24 h, or 12 h with a volume of media (EpiLife with EDGS) equal to two-fifths of the surface area of the flask (Fig 1).

### Bioreactor

A list of all of the parts of the bioreactor system is provided in Table 1. A schematic representation of the finished bioreactor system is shown in Figure 4. The BF is secured to the rocker (RK-250; Bioreactor Sciences, Lawrenceville, GA, USA), and assembly of the bioreactor system occurs as described in the following paragraph.

A 0.2 µm inline air filter, (EMD Millipore, MTGR05010, Burlington, MA, USA) is attached to the gas line on the BF, at line C (Fig 3). Tygon tubing 3350 is run from the air filter inlet to the fine supply outlet column on the rotameter (GB-100; Bioreactor Sciences). The rotameter is adjusted to the minimum flow rate using the tuning dial on the fine supply wheel.

**Table 1** Bioreactor system components.

Component	Purpose	Source
5% CO <sub>2</sub> 95% Air Compressed #5 Gas Cylinder	To provide 5% CO <sub>2</sub> and air to the cell culture and to provide a driving force for emptying of used media and ePUKs (daughter cells)	Cryogenic Gasses Inc.
Inline Filter, 0.2 µm	Filter gas from gas cylinder to BF	Millipore MTGR05010
Incubator, 37°C	To provide a 37°C environment	Thermo Forma model 3110
Class 2A Biological Safety Cabinet	To house and allow maintenance of Media reservoir and ePUK harvest flask.	Thermo Forma model 1214
Bioreactor Culture Flask 75 cm <sup>2</sup> (BF)	To serve as the parent monolayer growth vessel, BF	Corning 430641 Modified by investigators as described.
ePUK harvest flask	To catch the daughter cells, ePUKs	Corning, 430641
Rotameter	Reduce air volume from compressed gas cylinder	Bioreactor Sciences GB-100
Peristaltic pump	Pump fresh media from media reservoir to the BF	Bioreactor Sciences PP-100
Programmable rocker	Tilt parent monolayer culture flask for ePUK harvest	Bioreactor Sciences RK-250
Fresh media reservoir bottle	To supply fresh media to BF	Bioreactor Sciences
Tygon tubing 3350 ID 3/16-inch, OD 5/16-inch	Deliver media to and remove ePUKs and spent media from the BF	Cole Parmer, VV-95702-09
Tygon tubing 3350 ID 3/32-inch, OD 5/32-inch	Create a narrower transit system with less void volume between BF and fresh media reservoir and between BF and ePUK harvest flask	Cole Parmer VV-95702-03
Tubing connector	To connect narrower Tygon tubing used for transit to wider tubing connected to BF	Cole Parmer Masterflex 30616-59
Clear Gorilla Epoxy cat# 5242742001	To adhere and seal with integrity Tygon tubing to BF Corning flask and flask cap.	Department Store Meijer

Only the fine supply is used for this bioreactor. The rotameter fine supply column inlet is connected to a gas regulator and 5%CO<sub>2</sub>, 95% air compressed gas cylinder (Cryogenic Gases, Detroit, MI, USA). Tygon tubing with an inner dimension of 3/32-inch and outer dimension of 5/32-inch, is used as the long distance carrier, transit line, between the media fill line of the BF and the peristaltic pump, and also between the aspiration line of the BF and the ePUK harvesting flask. Tubing connectors (30616-59; Cole-Parmer, Vernon Hills, IL, USA), are used to join the narrower transit lines to their wider BF connection lines (Fig 3) – lines A and B. The narrower tubing was chosen for the transit lines due to its lower volume, thus enabling a rapid flow preventing settling of ePUKs and allowing for transit of fluids around corners as necessary within the laboratory setting. The ePUK harvest flask and fresh media reservoir are housed within a laminar flow hood adjacent to the incubator housing the BF. The ePUK harvest flask can be as simple as a Corning flask (430641; Corning, NY, USA) with the ePUK harvest line left to empty into the uncapped neck of the flask. The BSL2 laminar flow hood provides an aseptic environment for filling the fresh media reservoir and also for collecting the harvested ePUK cells. The gas line constantly provides 5%CO<sub>2</sub> and 95% air into the BF; the gas does not stop and is not controlled beyond setting the rotameter to a minimum flow. The rocker is programmed to tilt 30 degrees with a speed of 3.8 rock/min. This speed and degree of tilt was effective to re-suspend the non-adherent cells so that they would float within the media and be available for collection. The rocker performs a single rock to the backside of the BF, holds the position for 2 s, and then rocks to the neck of the flask and holds the position for 15 s. The rock to the backside of the BF with a 2 s hold allows the non-adherent cells to become suspended within the media of the BF. The 45 s hold at the neck of the BF allows all of the media volume of the BF to be forced, by positive air pressure due to the constant flow of 5% CO<sub>2</sub> and 95% air into the BF, into the bioreactor flask aspiration line. After the 45 s hold the rocker returns to the horizontal position. The rocker is programmed to hold this horizontal position for 17 h, 58 min 55 s. The remaining 17 s of an 18 h period are utilised by the tilt of the rocker, first to the backside, and then to the neck of the BF. The peristaltic pump, PP-100 (BioReactor Sciences), is synchronised with the rocker to fill the BF with 30 ml of fresh media (a volume equal to two-fifths of the surface area of the flask, as used in the manual ePUK control culture arm) after the rocker returns to the horizontal position. The peristaltic pump was set to a speed of 20 RPM and

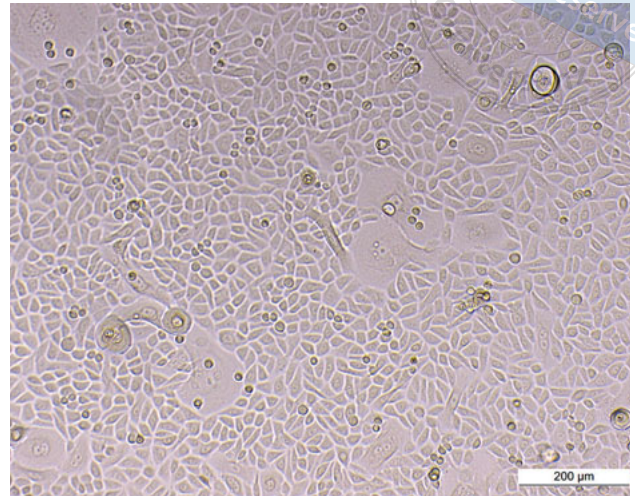

**Fig 5** Photo of the manual ePUK control culture flask monolayer on the ninth day of the experiment reveals a parent monolayer of mixed cell sizes.

could deliver the 30 ml of fresh media in 1 min 40 s. During the 32 days that the bioreactor was tested (Fig 2) the timing of ePUK collection was revised in order to maintain sufficient glucose availability within the BF. As the parent monolayer produced more cells during each time period, the demand for additional nutrition also increased based on glucose consumption measurements of harvested media from the ePUK harvest flask. For this reason, on day 14 (Fig 2), the rocker's horizontal hold period was decreased to 11 h 58 min 55 s, providing a 12 h cycle period, and the peristaltic pump was synchronised to fill the BF with 30 ml at the beginning of the horizontal hold. Similarly, on day 29 the horizontal hold period was decreased to 7 h 58 min 55 s, providing an 8 h cycle period, due to the continued use of available glucose within the bioreactor flask.

#### *Glucose measurements*

Glucose consumption was tracked in order to ensure that the glucose needs of the cells within the bioreactor were being met. The glucose measurements were generated using a laboratory glucometer, BRS GM-100 (BioReactor Sciences).

#### *Cell size and viability of ePUKs*

The number of ePUK cells produced by the bioreactor, and the size of those cells was determined by cell counting with a Countess Automated Cell Counter

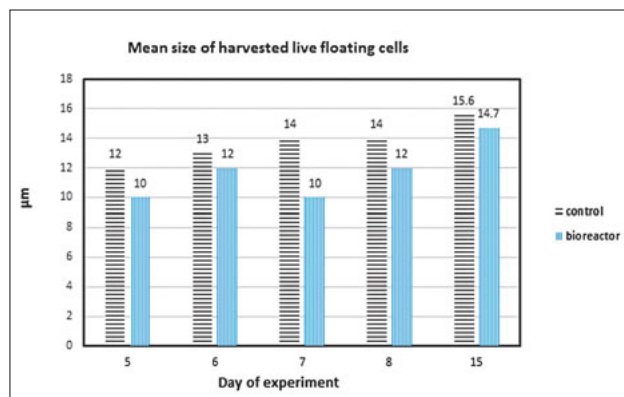

**Fig 6** Mean size of harvested live floating cells: Shows the mean size, in micrometers, of live floating cells harvested from (1) the manual ePUK control culture flask (fed every 24 h) and (2) for live floating cells harvested from the bioreactor (fed every 18 h). There is a trend for the harvested bioreactor cells to be smaller in size.

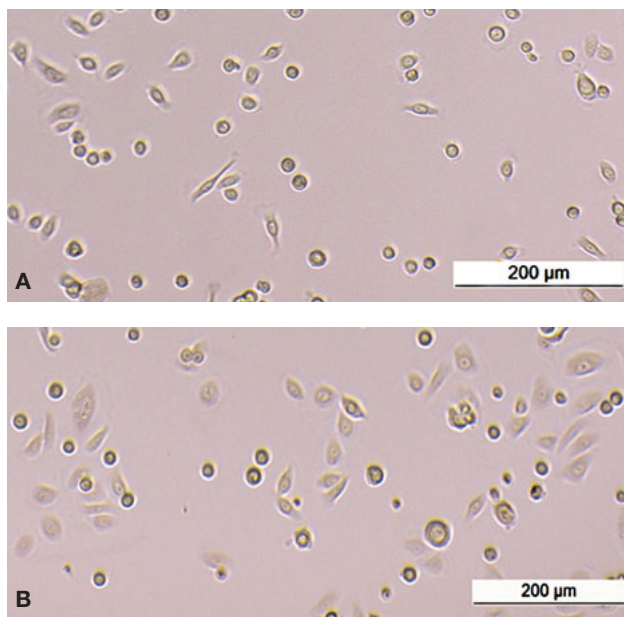

**Figs 7A and B** Photograph of sub-cultured floating cells produced by the bioreactor A (18 h feeding schedule) and by the manual ePUK culture method B (24 h feeding schedule) on the 8th day of the experiment. Note the smaller size of cells produced by the bioreactor A, compared to the larger cells of the manual ePUK control culture B.

(Invitrogen, Carlsbad, CA, USA). The viability of the ePUKs produced was determined by harvesting and sub-culturing them in a new flask, using the manual ePUK control culture method. Subcultures that continue to proliferate and are free of contamination are viable.

### Microscopy

Imaging of the cells was performed using a Leica DMI 4000B microscope.

### Results

The BF remained connected as a part of the total bioreactor system and was not moved. Cells within the BF were not visualised until day 37, the final day of the study. A manual ePUK control culture flask of the same age and lineage as the bioreactor parent monolayer was maintained in parallel with the bioreactor arm of the study and served as a control arm comparison. No prophylactic chemicals or antibiotics were used in the bioreactor or in the manual ePUK control culture. On day 37, microscopic inspection of the bioreactor flask revealed no contamination by microorganisms.

Our developed bioreactor did not have the ability to constantly monitor glucose. The feeding intervals of every 18 h, 12 h, or 8 h were programmed in response to the glucose levels of spent media harvested from the BF. In order to compare the use of a bioreactor to the published ePUK culture method<sup>1</sup> the manual ePUK control culture flask was fed every 24 h with a volume equal to two-fifths of the surface area of the flask. In her paper, Marcelo states: “Any break in the ePUK protocol resulted in reduced cell number and viability in the ePUK suspension...” Feeding the control flask once every 24 h limited the number of days that healthy ePUKs were produced by the control flask. A photo of the manual ePUK control culture monolayer on the ninth day of the experiment shows a monolayer of mixed size cells (Fig 5). Viable ePUKs, determined by their ability to be sub-cultured, attach and proliferate, were produced by the manual ePUK control culture flask until day 11. The relative size of cells harvested from both the bioreactor and the control flask is shown in Figure 6. The cell size collected from the bioreactor with an 18 h feeding cycle tended to be slightly smaller than the cell size collected from the 24 h feeding cycle of the manual ePUK control culture.

Photos of subculture flasks of the day 8 cell harvests from the bioreactor (Fig 7A) and from the manual ePUK control culture flask (Fig 7B) demonstrated observable signs of viable cells, but the cells produced by the manual ePUK control culture were noticeably larger. The manual ePUK control culture flask was changed to a 12 h feeding schedule at the same time as the bioreactor on day 14 (Fig 1). For days 15 to 21 the control manual ePUK control culture flask demonstrated about half as much glucose consumption (Fig 8) as the experimental bioreactor (Fig 9).

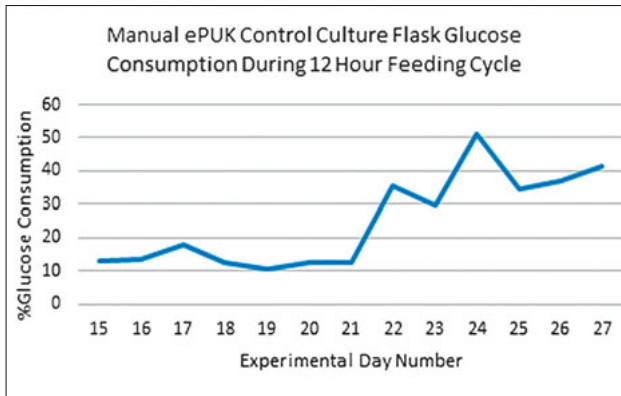

**Fig 8** Shows daily percentage glucose consumption of the manual ePUK control culture flask during the 12 h feeding cycle. The lower consumption of glucose during days 15 through to 21 demonstrates the effect of damage to the monolayer of the control flask due to insufficient feeding during the 24 h feeding cycle on days 4 through to 14.

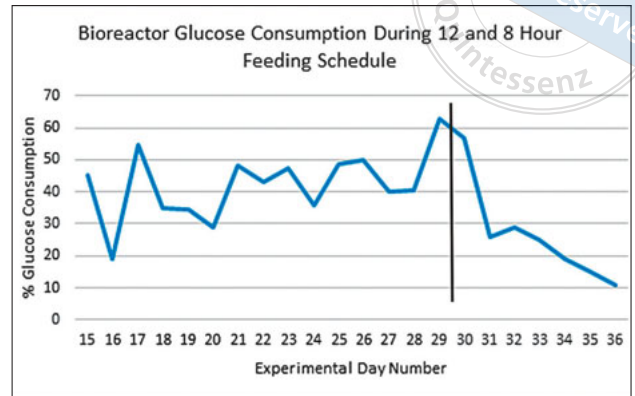
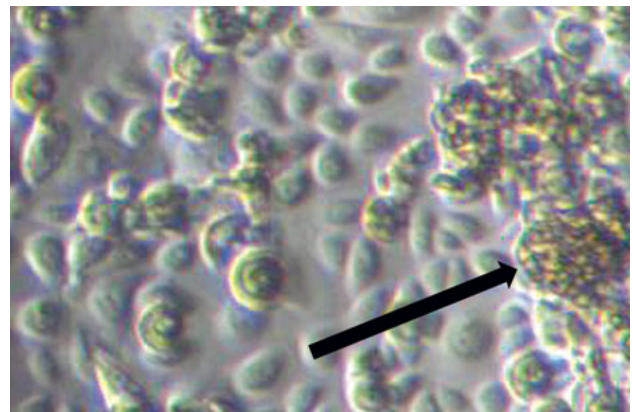

**Fig 9** Shows daily percentage glucose consumption from the bioreactor during days 15 through to 36. The vertical line between day 29 and day 30 shows the separation of the end of the 12 h feeding cycle and the beginning of the 8 h feeding cycle. Glucose consumption on day 29 was 63%, creating a physiologic glucose level less than normal, which likely caused damage to the parent monolayer of the bioreactor flask, which resulted in decreased glucose consumption the following days.

On day 22, the glucose consumption of the manual ePUK control culture flask had increased to 35.6% approximating the glucose consumption of the bioreactor flask, 43%. Subcultures produced from both the bioreactor and the ePUK control culture flask were viable and prolific when the timing of media exchange matched the glucose demand of the cells to a value near 45% glucose consumption. The manual ePUK control culture flask was followed until day 27 (Fig 8), with the expectation that the bioreactor would soon be changed to an 8 h cycle. Performing the manual ePUK control culture media exchanges every 8 h was not included in this study because its original intent was to evaluate the usability of a bioreactor in the ePUK culture method and compare it to the published 24 h manual feeding method.

On day 29, the bioreactor was changed to an 8 h feeding schedule. The glucose consumption on day 29 was 63% (Fig 9) and the viability of harvested cells decreased, as did glucose consumption during the following days until the study ended on day 37.

The total culture period for the BF was 37 days. On the final day, photos were taken of the bioreactor monolayer (Fig 10). Aggregates of many cells are found sticking on top of the bioreactor monolayer cells. The glucose consumption decreased from the 29th day when the percent glucose used during the 12 h feeding period was 63%. As previously observed on day 17, when glucose usage is high – above 50% – the parent monolayer will be affected.



**Fig 10** Photograph of bioreactor parent monolayer on day 37 of the experiment. Clumps, indicated by the arrow, show small round cell aggregates seen on top of the parent monolayer. This clumping of floating cells, indicative of cell death, correlates with the decrease in glucose consumption beginning on day 30. Despite not using any antibiotics or prophylactic chemicals no signs of contamination or sterility breach were observed.

## Discussion

Use of this bioreactor cell culture strategy demonstrated that the ePUK culture method is amenable to the automated production of ePUK cells. Future advances may make it possible for a bioreactor to produce hundreds of thousands of keratinocytes per min. The cells produced in our bioreactor were sensitive to forces exerted by

centrifugation. It is not known if the cells could tolerate the force of centrifugation if they had been collected at an earlier time point, such as within 1 min of cytokinesis. The delay between cytokinesis and cell harvest may have resulted in the creation of a fragile cell membrane as the cells are grown in an essential fatty acid deficient medium, EpiLife, without serum. As previously described by Kato et al<sup>6</sup>, the cells collected by the ePUK technique contain all floating cells, and these floating cells are of varying size, age, and viability.

The lack of an integrated glucose measurement system to automatically determine cycle time presented problems in our study. Measuring the glucose level of the media at the time of ePUK harvest meant we were always behind in determining the nutrient needs of the parent monolayer. Had the bioreactor contained an integrated glucometer to constantly monitor the glucose levels and automatically adjust the feeding/harvest interval, then the quality of the ePUKs produced and the functional longevity of the parent monolayer may have been further preserved.

Figure 9 shows a continuing decline of glucose consumption following the high level of glucose consumption on day 29. The glucose content of EpiLife is near that of normal human blood glucose – 114 mg/dL. Similar to that seen in type I diabetes, cells in culture are damaged when sufficient glucose is not available<sup>7</sup>. Our glucose measurements were taken at the time of media exchange, and therefore reflect the low points of glucose availability. In Figure 9, glucose consumption of about 45% – equalling an available glucose level of 62 mg/dL remaining in the spent media – was not problematic. Physiologic blood glucose levels below 54 mg/dL are recognised as dangerous. On day 29, when the glucose consumption was 63%, the glucose level of the media decreased to 42 mg/dL and resulted in a decline of the culture. If sufficient nutrition levels are quickly restored to the culture then the parent monolayer can recover, but a temporary setback in glucose consumption occurs, as seen in Figure 8 on days 15 through to 21. Although the manual ePUK control culture started a 12 h feeding schedule on day 15, the glucose consumption of that control flask did not reach levels of glucose consumption similar to the experimental bioreactor flask until day 22. This is attributed to damage, which occurred during the latter days of the 24 h feeding schedule of the control flask in contrast to the 18 h feeding schedule of the bioreactor flask.

On day 22, the manual ePUK control culture began consuming more glucose, which is indicative of the restoration of a viable parent monolayer. Although the experimental bioreactor parent monolayer could not be

visualised, the glucose consumption of the bioreactor and the viability of the ePUKs produced by the bioreactor on days 17 to 21 demonstrated that the bioreactor monolayer was healthy. Starting the bioreactor with an 18 h feeding schedule, rather than a 24 h feeding schedule, prolonged the health of the bioreactor parent monolayer.

Cells obtained from different individuals are likely to mature and grow with different potency and, for this reason, it is optimal for a scientist to be able to visually assess a monolayer and make observation-based adjustments to cell cultures as needed. Any observed clumping of the cells in this experiment would have been abnormal, and indicate a problem; perhaps not all of the suspended daughter cells – ePUKs – were being removed at the time of media exchange. Observations of a detaching monolayer would also indicate a problem in the culture. However, observation of the bioreactor parent monolayer was not possible in this study due to the lack of an integrated camera capable of visualising the parent monolayer cells. Addition of a camera allowing observation of the bioreactor parent monolayer without invasive manoeuvres, such as disassembly of the bioreactor, could have aided in a more rapid detection of problems. In our bioreactor 5% CO<sub>2</sub>, 95% air was constantly being delivered. The amount of gas being utilised is relatively small, but our team recognises that on-demand gas delivery and synchronisation with the rocker is an important consideration for future development. The bioreactor was effective in automating the feeding of the parent monolayer and automating the ePUK collection process without the use of trypsin or enzymes taking advantage of this novel culturing process. Enzymatic harvesting of adherent cells changes the structure of the proteins on the cell membrane modifying their analysable phenotype.

Enzymatic harvest may also impact the viability of a cell, which may affect experimental results. The bioreactor allowed for a closed culture system with less risk of technician error and contamination. Harvesting the ePUKs by removing all of the media at one time offers the best chance for harvesting all of the ePUKs produced so that they do not die within the culture. An improved technology for more frequent ePUK collection without removal of all of the media will make more efficient use of media and be more cost effective. Such a system might add glucose on demand rather than completely changing all of the media. Improvements such as an all-in-one design that does not rely upon the use of an incubator for temperature control or a laminar flow hood for sterile operations would maximise the utility of the bioreactor. A smaller footprint would also



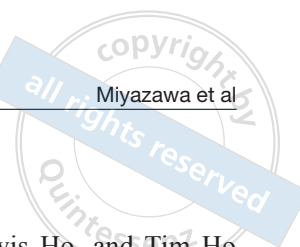

decrease the need for long distance transit lines, which did not cause a problem in this study, but are a flaw nonetheless.

Keratinocytes become larger as they age<sup>8</sup>. The larger size of the keratinocytes in the manual ePUK control culture may be indicative of aging due to insufficient culture maintenance, specifically media changes (glucose levels), resulting in age progression. The cell content collected from both the bioreactor and from the manual ePUK culture each contains cells of varied levels of differentiation and ageing. Some are newly cytokinesed ePUKs while some may be older cells that have separated from the parent monolayer secondary to cell differentiation.

## Conclusion

ePUK cells can be produced both manually and by an automated process. Feeding the parent monolayer more frequently in response to glucose consumption allows continued ePUK production to occur. Feeding the parent monolayer, a volume equal to two-fifths of the surface area of the flask, every day does not allow for an extended culture period. As the culture duration progresses, the parent monolayer requires more media and more frequent media changes. Addressing these needs in a timely fashion may be a way of extending the longevity of the cell culture.

Through the mechanism of contact inhibition, a bioreactor can enable collection of daughter cells of normal epithelial progeny soon after cytokinesis, while still in a floating non-adherent state prior to flask attachment. Harvesting of these floating cells prior to adherence would allow these cells to be studied more thoroughly. Future studies of daughter cells harvested soon after cytokinesis may reveal important information about cell development. An improved understanding of cell development can result in new therapeutic targets for a myriad of diseases, including viral infections and cancer. The development of an automated and continuously operating bioreactor may be a means by which large quantities of adherent epithelial cells could be produced for use in tissue engineering/regenerative medicine protocols.

## Acknowledgements

We would like to thank Drs Lewis Ho, and Tim Ho of Bioreactor Sciences LLC, Lawrenceville, Georgia, USA, for their developmental assistance and the use of necessary equipment, including the rotameter, rocker, pump, fresh media reservoir and glucose meter. We would like to thank Dr Cynthia Luz Marcelo for inspiring the study and advising with regard to the culture of keratinocytes and ePUKs.

## Conflicts of interest

The authors reported no conflicts of interest related to this study.

## Author contribution

Drs Atsuko Miyazawa, James Washington, Eve Bingham, and Stephen Feinberg developed the scientific plan; Drs Miyazawa and Washington performed the experiments and data collection; Drs Miyazawa, Washington, Bingham, Kuo, and Feinberg analysed data, prepared and revised the manuscript.

(Received Nov 17, 2017; accepted Dec 15, 2017)

## References

1. Marcelo CL, Peramo A, Ambati A, Feinberg SE. Characterization of a unique technique for culturing primary adult human epithelial progenitor/"stem cells". *BMC Dermatol* 2012;12:8.
2. Izumi K, Neiva RF, Feinberg SE. Intraoral grafting of tissue-engineered human oral mucosa. *Int J Oral Maxillofac Implants* 2013;28:e295–303.
3. Kato H, Marcelo CL, Washington JB, Bingham EL, Feinberg SE. Fabrication of Large Size Ex Vivo-Produced Oral Mucosal Equivalents for Clinical Application. *Tissue Eng Part C Methods* 2015;21:872–880.
4. Hay RJ. Operator-induced contamination in cell culture systems. *Dev Biol Stand* 1991;75:193–204.
5. Fujimori Y, Izumi K, Feinberg SE, Marcelo CL. Isolation of small-sized human epidermal progenitor/stem cells by Gravity Assisted Cell Sorting (GACS). *J Dermatol Sci* 2009;56:181–187.
6. Kato H, Lo A, Kuo S, et al. Proteomics Characterization of Primary Human Oral Epithelial Cells Using a Novel Culture Technique for Use in Tissue Regeneration. *MOJ Proteom Bioinform* 2015;2:52.
7. Caro-Maldonado A, Muñoz-Pinedo C. Dying for Something to Eat: How Cells Respond to Starvation. *Open Cell Signaling Journal* 2011;3:42–51.
8. Liao YH, Chen SY, Chou SY, Wang PH, Tsai MR, Sun CK. Determination of chronological aging parameters in epidermal keratinocytes by in vivo harmonic generation microscopy. *Biomed Opt Express* 2013;4:77–88.